

# QUANTUM 1310MG

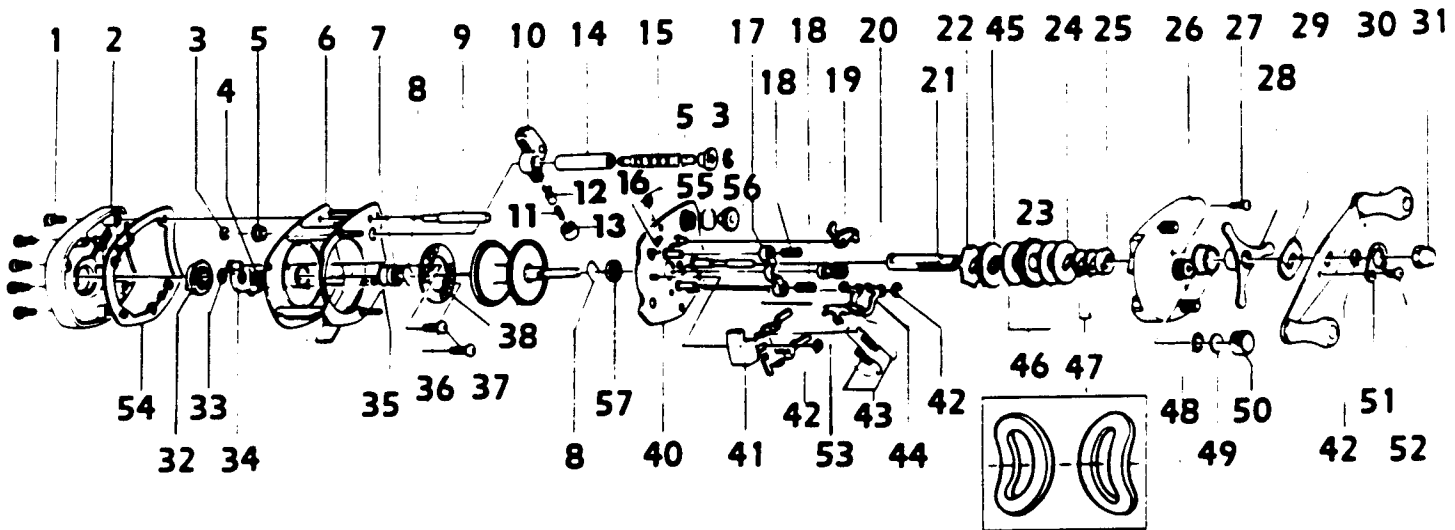

Key No.	Part No.	Description	Price	Key No.	Part No.	Description	Price
	CX4000	SPARE PARTS W/WRENCH	3.69	28	NX4663	STAR DRAG	5.21
	NX4100	LEVEL WIND HOOD	4.85	29	CX4660	HANDLE WASHER	.36
	T130	WRENCH	2.59	30	NX4701	HANDLE ASSY.	6.14
1	LX4102	RIGHT SIDE PLATE SCR.	.99	31	NX4702	HANDLE NUT	.91
2	NX4101	LEFT SIDE PLATE	7.99	32	NX4303	MAGNETIC CONTROL DIAL	1.23
3	CX4152	WORM SHAFT RETAINER	.31	33	CX4250	O RING	.49
4	CX4301	MAGNET RET. SPRING	.36	34	CX4261	MAGNET RET. SUPPORT	1.46
5	CX4156	WORM GUARD BUSHING	.62	35	CX4255	SPOOL TENSION SHIM A	.36
6	NX4051	FRAME	21.49	36	CX4602	MAGNET RETAINER SCREW	.62
7	CX4252	SPOOL SHFT BEARING	7.99	37	CX4257	MAGNET RETAINER	8.59
8	CX4253	BEARING RETAINER	.36	38	CX4251	SPOOL ASSY	13.35
9	BX4159	FRAME POST- SILVER	1.53	40	NX4351	SET PLATE	18/36
10	NX4201	LINE GUIDE	7.55	41	NX4402	SPOOL RELEASE BUTTON	2.64
11	CX4203	LINE GUIDE PAWL SPRING	.36	42	CX4656	RETAINER CLIP	.36
12	CX4202	LINE GUIDE PAWL	2.21	43	CX4353	SET PLATE ACT. SPRING	.36
13	CX4204	PAWL CAP	.91	44	CX4503-1	SET PLATE ACTUATOR B	1.23
14	BX4158	WORM SHFT GUARD-SILVER	2.64	45	CX4658-2	ANTI-REVERSE RATCHET	6.89
15	CX4151-1	WORM SHAFT W/O GEAR	3.69	46	CX4661	DRAG WASHER A	.36
16	CX4502	SPOOL RELEASE SPRING	.36	47	CX4662	DRIVE SHAFT SPR. WSHR	.36
17	CX4401	PINION YOKE	.62	48	CX4258	O RING	.36
18	CX4403	PINION YOKE SPRING	.36	49	CX4302	SPOOL TENSION SHIM B	.36
19	CX4452-1	DOUBLE ANTI-REV PAWL	3.38	50	NX4259	SPOOL TENSION KNOB	2.40
20	NX4256	PINION GEAR	9.21	51	LX4703	HANDLE NUT LOCK	1.23
21	CX4652	DRIVE SHAFT	3.69	52	LX4704	HANDLE NUT LOCK SCR.	.49
22	CX4451-1	RELEASE RATCHET	1.23	53	CX4501-1	SET PLATE ACTUATOR A	1.23
23	NX4651	DRIVE GEAR	6.14	54	NX4107	LEFT SIDE PLATE SPACER	1.84
24	CX4659	DRAG WASHER B	.62	55	CX4153	GEAR RETAINING CLIP	.31
25	CX4254	DRIVE SHFT BUSH	.62	56	NX4150	WORM SHAFT GEAR	4.31
26	NX4103	RIGHT SIDE PLATE	17.14	57	CX4252	SPOOL SHFT BEARING	7.99
27	LX4352	LEFT SIDE CVR SCREW	.42				

Prices subject to change without notice. Prices do not include postage and handling.

**PLEASE ORDER BY PART NUMBER**

Rev. 5/93

Zebco Division Brunswick Corporation, Box 270, Tulsa, OK 74101 USA 918-836-5581

